

### 40 mm, 57 mm, 75 mm Carbo Ratchets

USA – Tel: (+01) 262-691-3320 • Web: www.harken.com • Email: harken@harken.com  
 Italy – Tel: (+39) 031.3523511 • Web: www.harken.it • Email: techservice@harken.it



Strictly follow all instructions to avoid an accident, damage to your vessel, personal injury or death. See [www.harken.com](http://www.harken.com) for additional safety information.

**IMPORTANT: See Inspection and Maintenance at end of manual.**

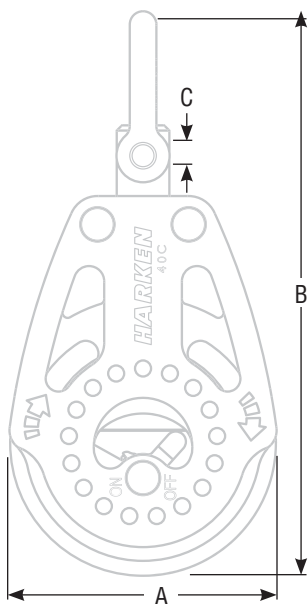

#### Features

**Glass-filled nylon sideplates:** load-carrying curved bearing races.

**Machined Hardkote-anodized aluminum sheaves:** strength and corrosion resistance.

**Eight-facet sheave:** holds line securely.

**Ratchet on/off switch:** 40 mm–2608/2609/2614; 57/75 mm—all blocks.

**Ratchet always on:** 2610/2611.

**Cam arm locking plates:** Allows cam arms to be locked in more than five positions for fair leads.

**Cheek:** Line-shedding, small mounting footprint and drain holes.

**Common uses:** Main/jib/spinnaker sheets/traveler controls/genoa sheets/foreguys

Part No.	Description	A		B		C		Max line Ø		Maximum working load*		Breaking load*	
		in	mm	in	mm	in	mm	in	mm	lb	kg	lb	kg
<b>40 mm</b>													
2608	Single/swivel	1 <sup>1</sup> / <sub>16</sub>	40	3 <sup>3</sup> / <sub>8</sub>	86	5 <sup>5</sup> / <sub>32</sub>	4	3 <sup>3</sup> / <sub>8</sub>	10	300	136	1000	454
2609	Single/swivel/becket	1 <sup>1</sup> / <sub>16</sub>	40	4	102	5 <sup>5</sup> / <sub>32</sub>	4	3 <sup>3</sup> / <sub>8</sub>	10	300	136	1000	454
2610	Single/swivel/471 Carbo-Cam®*	1 <sup>1</sup> / <sub>16</sub>	40	3 <sup>3</sup> / <sub>8</sub>	86	5 <sup>5</sup> / <sub>32</sub>	4	1 <sup>1</sup> / <sub>4</sub>	6	150	68	300	136
2611	Single/swivel/471 Carbo-Cam®/becket*	1 <sup>1</sup> / <sub>16</sub>	40	4	102	5 <sup>5</sup> / <sub>32</sub>	4	1 <sup>1</sup> / <sub>4</sub>	6	300	136	600	272
2612	Triple/swivel/471 Carbo-Cam®**	1 <sup>1</sup> / <sub>16</sub>	40	3 <sup>11</sup> / <sub>16</sub>	94	3 <sup>3</sup> / <sub>16</sub>	5	1 <sup>1</sup> / <sub>4</sub>	6	750	340	1500	680
2613	Triple/swivel/471 Carbo-Cam®/becket	1 <sup>1</sup> / <sub>16</sub>	40	4 <sup>3</sup> / <sub>16</sub>	110	3 <sup>3</sup> / <sub>16</sub>	5	1 <sup>1</sup> / <sub>4</sub>	6	900	408	1800	816
2614	Cheek	1 <sup>1</sup> / <sub>16</sub>	40	2 <sup>3</sup> / <sub>4</sub>	70	—	—	3 <sup>3</sup> / <sub>8</sub>	10	300	136	1000	454
2619	Triple/471 Carbo-Cam®/29 mm/becket	1 <sup>1</sup> / <sub>16</sub>	40	4 <sup>3</sup> / <sub>4</sub>	121	3 <sup>3</sup> / <sub>16</sub>	5	1 <sup>1</sup> / <sub>4</sub>	6	900	408	1800	816
<b>57 mm</b>													
2135	Single/swivel	2 <sup>1</sup> / <sub>4</sub>	57	4 <sup>1</sup> / <sub>16</sub>	103	3 <sup>3</sup> / <sub>16</sub>	5	3 <sup>3</sup> / <sub>8</sub>	10	500	227	2000	907
2136	Single/swivel/becket	2 <sup>1</sup> / <sub>4</sub>	57	4 <sup>15</sup> / <sub>16</sub>	125	3 <sup>3</sup> / <sub>16</sub>	5	3 <sup>3</sup> / <sub>8</sub>	10	500	227	2000	907
2137	Cheek	2 <sup>1</sup> / <sub>4</sub>	57	3 <sup>3</sup> / <sub>4</sub>	83	—	—	3 <sup>3</sup> / <sub>8</sub>	10	500	227	2000	907
2138	Single/swivel/150 Cam-Matic®*	2 <sup>1</sup> / <sub>4</sub>	57	4 <sup>1</sup> / <sub>16</sub>	103	3 <sup>3</sup> / <sub>16</sub>	5	3 <sup>3</sup> / <sub>8</sub>	10	300	136	750	340
2139	Single/swivel/150 Cam-Matic®/becket*	2 <sup>1</sup> / <sub>4</sub>	57	4 <sup>15</sup> / <sub>16</sub>	125	3 <sup>3</sup> / <sub>16</sub>	5	3 <sup>3</sup> / <sub>8</sub>	10	600	272	1500	680
2140	Triple/swivel/150 Cam-Matic®**	2 <sup>1</sup> / <sub>4</sub>	57	4 <sup>1</sup> / <sub>16</sub>	103	3 <sup>3</sup> / <sub>8</sub>	10	1 <sup>1</sup> / <sub>4</sub>	6	1500	680	3750	1700
2141	Triple/swivel/150 Cam-Matic®/becket	2 <sup>1</sup> / <sub>4</sub>	57	4 <sup>15</sup> / <sub>16</sub>	125	3 <sup>3</sup> / <sub>8</sub>	10	1 <sup>1</sup> / <sub>4</sub>	6	1800	816	4500	2041
2673	57 mm fiddle/ratchet	2 <sup>1</sup> / <sub>4</sub>	57	4 <sup>3</sup> / <sub>8</sub>	118	3 <sup>3</sup> / <sub>8</sub>	10	3 <sup>3</sup> / <sub>16</sub>	5	793	360	2380	1080
2674	57 mm fiddle/ratchet/becket	2 <sup>1</sup> / <sub>4</sub>	57	5 <sup>5</sup> / <sub>8</sub>	143	3 <sup>3</sup> / <sub>8</sub>	10	3 <sup>3</sup> / <sub>16</sub>	5	793	360	2380	1080
2675	57 mm fiddle/ratchet/150 Cam-Matic®	2 <sup>1</sup> / <sub>4</sub>	57	4 <sup>3</sup> / <sub>8</sub>	118	3 <sup>3</sup> / <sub>8</sub>	10	3 <sup>3</sup> / <sub>16</sub>	5	793	360	2380	1080
2676	57 mm fiddle/ratchet/150 Cam/becket	2 <sup>1</sup> / <sub>4</sub>	57	5 <sup>5</sup> / <sub>8</sub>	143	3 <sup>3</sup> / <sub>8</sub>	10	3 <sup>3</sup> / <sub>16</sub>	5	793	360	2380	1080
<b>75 mm</b>													
2670	Single/swivel	2 <sup>15</sup> / <sub>16</sub>	75	5 <sup>3</sup> / <sub>8</sub>	137	1 <sup>1</sup> / <sub>4</sub>	6	7 <sup>1</sup> / <sub>16</sub>	12	750	341	3000	1361
2671	Single/swivel/becket	2 <sup>15</sup> / <sub>16</sub>	75	6 <sup>1</sup> / <sub>2</sub>	165	1 <sup>1</sup> / <sub>4</sub>	6	7 <sup>1</sup> / <sub>16</sub>	12	750	341	3000	1361
2672	Cheek	2 <sup>15</sup> / <sub>16</sub>	75	4 <sup>1</sup> / <sub>16</sub>	103	—	—	7 <sup>1</sup> / <sub>16</sub>	12	750	341	3000	1361
2694	75 mm fiddle/ratchet	2 <sup>15</sup> / <sub>16</sub>	75	6 <sup>3</sup> / <sub>16</sub>	157	1 <sup>1</sup> / <sub>2</sub>	12	1 <sup>1</sup> / <sub>4</sub>	6	1212	550	3637	1650
2695	75 mm fiddle/ratchet/becket	2 <sup>15</sup> / <sub>16</sub>	75	7 <sup>1</sup> / <sub>16</sub>	189	1 <sup>1</sup> / <sub>2</sub>	12	1 <sup>1</sup> / <sub>4</sub>	6	1212	550	3637	1650
2696	75 mm fiddle/ratchet/150 Cam-Matic®***	2 <sup>15</sup> / <sub>16</sub>	75	6 <sup>3</sup> / <sub>16</sub>	157	1 <sup>1</sup> / <sub>2</sub>	12	1 <sup>1</sup> / <sub>4</sub>	6	900	408	3350	1020
2697	75 mm fiddle/ratchet/150 Cam/becket	2 <sup>15</sup> / <sub>16</sub>	75	7 <sup>1</sup> / <sub>16</sub>	189	1 <sup>1</sup> / <sub>2</sub>	12	1 <sup>1</sup> / <sub>4</sub>	6	1212	550	3637	1650

\*Maximum working loads and breaking loads for blocks based on cam strengths \*\*Can be used as becket block – add 281 eyestrap \*\*\*Can be used as becket block – add 137 eyestrap and (2) HFS929 panhead screws (M5X45) \*\* Can be used as becket – add 137 eyestrap

#### Ratchet Blocks

Ratchet blocks are hand and crew savers. The eight-sided sheave grips loaded sheets with up to 15: 1 holding power yet allows a line to be eased instantly with control. They allow the crew to hand hold main, jib and spinnaker sheets with only a fraction of the effort that a regular block requires. An on/off switch allows the ratchet to be turned off in light air to trim and ease lines more easily.

#### 40 mm

The 2608, 2609 and 2614 have on/off switches; other 40 mm ratchet blocks are always in ratchet mode.

#### 57 mm (10:1 Holding Power), 75 mm (15:1 Holding Power)

All 57 and 75 mm ratchet blocks have on/off switches.



## Ratchet Direction

Arrow on side of block shows direction that sheave will spin when ratchet is switched on. Refer to arrow when reeving block or mounting cheek block.

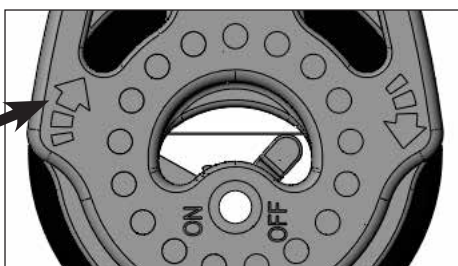

## 2614 / 2137 / 2672 Cheek Block

Position block so ratchet turns in desired direction. Flip block to change direction. Use chart below or use block as a template. Mark holes using centerpunch. Check marks with block before drilling. Remove block and drill holes using drill size from chart below. Bevel top of deck holes using a small knife to allow sealant to mass. Place gasket under block. Through-bolt block using recommended stainless steel fasteners, washers and locknuts.

**Ratchet cheek blocks include metric panhead screws, washers and nuts. See chart below:**

Block Part No.	Block Size	Drill Size		Block Thickness (G)		Supplied Fastener x Length
		mm	in	mm	in	
2614	40 mm	3.25	1/8	22	7/8	M3 x 40 mm
2137	57 mm	4.25	11/64	25	1	M4 x 60 mm
2672	75 mm	5.25	13/64	31	1 1/4	M5 x 60 mm

\*Fastener length: Add deck thickness and overhang for nut and washer.

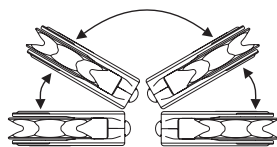

Block Size	Part No.	A		B		C		D		E		F	
		in	mm	in	mm	in	mm	in	mm	in	mm	in	mm
40 mm	2614	5/64	4	1 1/2	38	—	—	9/32	6.9	1 9/16	40	2 1/4	57
57 mm	2137	7/32	6	1 1/2	38	3/8	9.4	2 1/64	8.3	2 1/4	57	3 1/16	78
75mm	2672	9/32	7	2	51	1/2	12.7	3 1/64	12.4	2 15/16	75	4 1/16	103

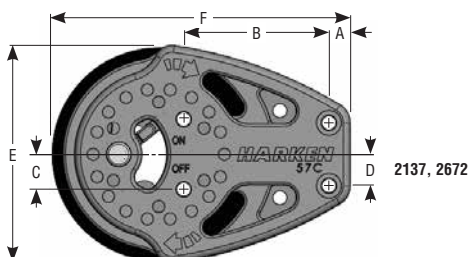
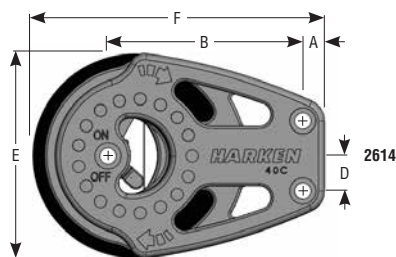

## 3-Way Cam-Lock – 2135 / 2136 / 2138 / 2139 / 2170 / 2171, 2673, 2674, 2675, 2676, 2694, 2695, 2696, 2697



1

1. Cam lever up. Block locks in front or side position.
2. Cam lever down. Block turns freely.



2

## 3-Way U-Lock – 2140 / 2141 / 2612 / 2613 / 2619

The 3-Way U-Lock on doubles and triples allows a change of headpost direction from front to side or allows the block to swivel. To change headpost direction, remove shackle, turn post, install shackle. Remove U-Lock to allow block to swivel.

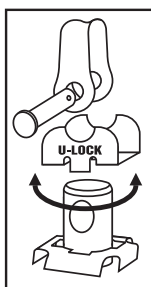

## Adjust Cam Angle (Single/40 mm)

1. Loosen cam arm locking plate screw and pull outward to disengage.
2. Rotate cam arm to desired position.
3. Press locking plate in and tighten screw. **Avoid binding sheave, do not over-tighten screw.**

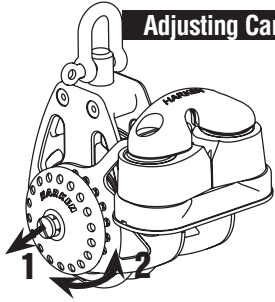

## Reverse Cam Cleat (Single Only)

1. Remove screws from cam.
2. Assemble as shown. Note: use plastic plate on cam bottom.
3. Tighten screws. **Do not overtighten screws. Cam pawls should snap shut smartly.**

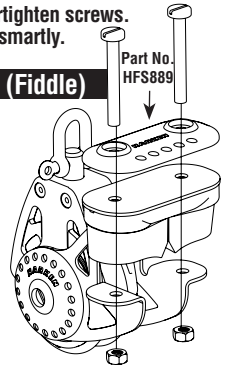

## Adjusting Cam Angle 57 mm (Single/Triple/Fiddle), 75 mm (Fiddle)

1. Remove **three** cam arm screws on each side.
2. Carefully note position of **three** screw holes in block (see diagram).
2. Rotate cam arm to desired position and line up cam arm holes with screw holes on block.
3. Insert screws into screw holes and tighten. **Do not overtighten screws or sheave will bind.**

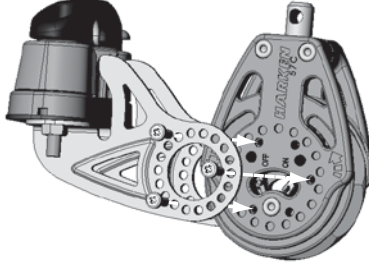

## Reeving Multi-Purchase Systems

Right-angle reeving dead-end on becket

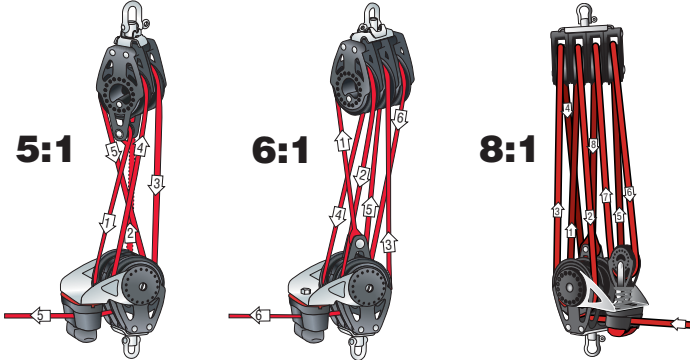

Right-angle reeving dead-end on cam

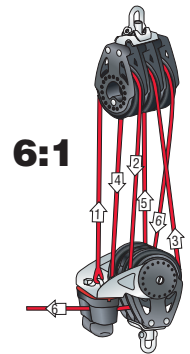

For larger, printable diagrams, please see: [www.harken.com](http://www.harken.com).

## Parts — 40 mm Carbo Ratchets

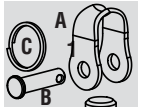

### 2608/2609 40 mm Single Ratchet

No.	Description	Qty	Part No.
1	Shackle Assembly Micro 5/32"		246
A	Shackle Strap	1	HSB104
B	Shackle Clevis Pin 5/32 X .488	1	HSB105
C	Split Ring	1	HSB24

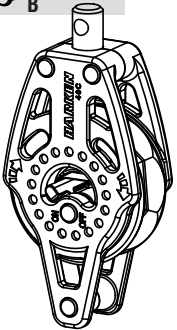

### 2610/2611 40 mm Single Ratchet w/471 Carbo Cam

1	Screw M3X30 Slotted Panhead	1	HFS888
2	Washer Cam Arm Left	1	H-26265B
3	Washer Cam Arm Right	1	H-27031B
4	Nut M3	1	HFS939
5	Cam Arm Left	1	H-46865
6	Cam Arm Right	1	H-46866
7	Nut M4	2	HFS890
8	Cam Cleat Micro Carbo	1	471
9	Micro Flairlead Black	1	424B
10	Cam Screws M4X30 Slotted Panhead	2	HFS889
11	Cam Plate for Reversing Cam	1	H-27034B
12	Shackle Assembly Micro 5/32"		246
A	Shackle Strap	1	HSB104
B	Shackle Clevis Pin 5/32 X .488	1	HSB105
C	Split Ring	1	HSB24

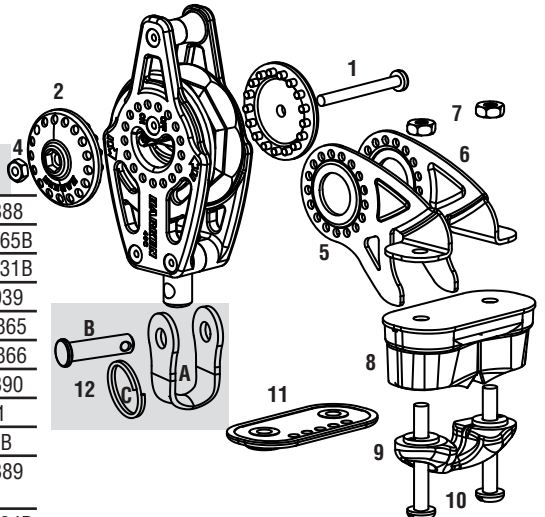

## Parts — 40 mm Carbo Ratchets

### 2612/2613 40 mm Triple Ratchet w/Carbo Cam

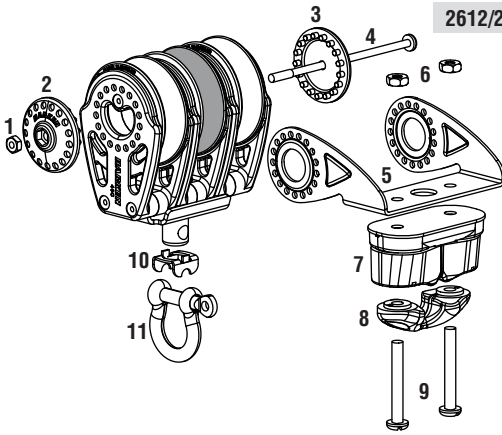

1	Nut M3	1	HFS939
2	Washer Left	1	H-26265B
3	Washer Right	1	H-27031B
4	Cam Arm Fastener M4X70 Custom	1	HFS895
5	Cam Arm	1	H-27052C
6	Cam Nut M4	2	HFS890
7	Cam Cleat, Micro Carbo	1	471
8	Micro Flairlead Black	1	424B
9	Cam Screw M4 X 30 Slotted Panhead	2	HFS889
10	U-Lock	1	H-27808A
11	Shackle 5mm Hybrid Shallow Bow	1	HCP1568

### 2619 40 mm Triple Ratchet/29 mm/Carbo Cam

1	Nut M3	1	HFS939
2	Washer Left	1	H-26265B
3	Washer Right	1	H-27031B
4	29mm 90 Degree Fixed Block	1	352
5	Spring	1	097
6	Eyestrapp, Micro	1	281
7	Cam Arm Fastener M4X70 Custom	1	HFS895
8	Cam Arm	1	H-27052C
9	Cam Nut M4	2	HFS890
10	Cam Cleat, Micro Carbo	1	471
11	Micro Flairlead Black	1	424B
12	Cam Screw M4 X 30 Slotted Panhead	2	HFS889
13	U-Lock	1	H-27808A
14	Shackle 5mm Hybrid Shallow Bow	1	HCP1568

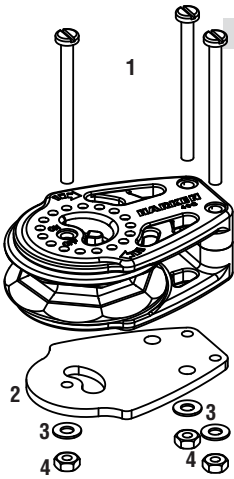
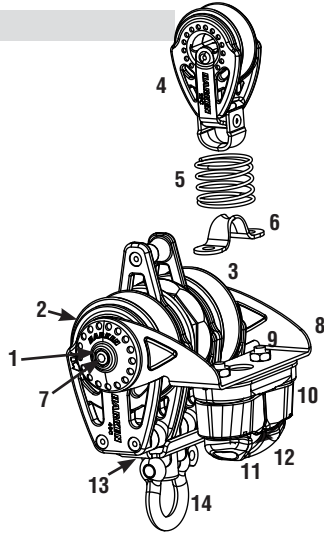

### 2614 40 mm Cheek Block

1	M3-.5X40mm Slotted Panhead Screw	3	HFS1014
2	Gasket	1	H-34924A
3	M3 Flatwasher	3	HFS1008
4	M3 Full Nut	3	HFS939

## Inspect Block and Shackle Before You Sail



**WARNING!** Failure to inspect and replace damaged metal parts and/or worn or frayed line can cause block or system to break suddenly causing an accident, damage to your vessel, personal injury or death. See [www.harken.com](http://www.harken.com) for additional safety information.

Frequently inspect shackles and shackle posts for signs of corrosion, cracks, or elongation. When replacing shackles, use the correct Harken parts to maintain the proper strength. Replace line as necessary, taking into consideration the maximum size recommendation.

## Maintenance

Harken equipment is designed for minimal maintenance. However, some upkeep is required to give the best service and comply with the Harken limited warranty.

Keep your equipment clean and free-running by frequently flushing with fresh water. Periodically clean with mild detergent and water solution. Spin sheaves to distribute soap solution evenly. Flush with fresh water.

**Important:** Exposure to some teak cleaners and other caustic solutions can result in discoloration of part and is not covered under the Harken warranty.

## Warranty

For additional safety, maintenance, and warranty information see [www.harken.com](http://www.harken.com) or the Harken catalog.